



SMPS600-R2

Single Rail SMPS

DATA SHEET

Switching power supply for audio applications

Sheet : 20042024

Revision 1.1.0

Features

- 110VAC / 240VAC Input (Selectable)
- Standby control input
- Onboard standby power supply 3W
- 18.8CM * 12.4CM * 5CM

Typical applications

- * Professional audio systems
- * Consumer audio products
- * HiFi audio systems

Highlights

- * High reliability
- * High efficiency
- * Low EMI signature



Image for reference only

Safety Warning

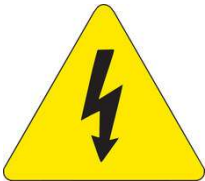

The **SMPS00-R2** operates at mains voltage and carries hazardous voltages up to **345VDC** at accessible parts. These parts may never be exposed to inadvertent touch.

Observe extreme care during installation and never touch any part of the unit while it is connected to the mains. Disconnect the unit from the mains and allow all capacitors to discharge for **5 minutes** before handling it.



IMPROPER HANDLING MAY RESULT IN PERSONAL INJURY



Ignoring the safety warning may lead to a nasty surprise on later stage!

Introduction

The SMPS600-R2 is an **unregulated** high efficiency switch mode power supply specifically designed for audio applications, where high system reliability is a required feature.

SMPS600-R2 also features an advanced over current protection & thermal protection, AC-Line loss detection to immediately stop the SMPS once disconnected from the AC-LINE.

This SMPS is the result of countless hours of design, development, testing for each circuit to combine one reliable product.

Detailed description of specifications

- Unregulated SMPS.
- Selectable input voltage range (110 VAC / 240 VAC). [Via jumper](#)
- Multiple output voltage range (+30 VDC ~ +80 VDC). [Selectable at order page](#)
- Standby switch input eliminates the need for mechanical switches.
- Onboard standby power supply (+12VDC or +5V 3W). [Selectable at order page](#)
- Regulated AUX output +-5 VDC ~ +-18 VDC. [Selectable at order page](#)
- AC-Line loss detection
- 12V Trigger input

The onboard standby power supply is always ON as long as the SMPS is connected to the AC-LINE

General Performance Data

Parameter	Symbol	Min	Typ	Max	Unit	Note-1	Note-2
Input voltage 110V	VAC_range_lo	110	120	135	V _{Ac}		
Input voltage 230V	VAC_range_hi	220	230	250	V _{Ac}		
Input frequency		47	50	63	Hz		
Switching frequency	F _{sw}	*	65	*	KHz		
Output voltage main	V _{main} output	40		84	V _{Dc}	Unregulated	Based on order For +55VDC as example
Output current (Continuous)	I _{main} output	10	12	13	A _{Dc}		
Output current (Peak)	IPK _{main} output	*	*	17	A _{Dc}		
Output power main	P _{out}	*	600	*	W		
Over current triggers @	OCP_trigger	*	18	19	A _{Dc}		Based on output voltage
Thermal trigger	TH_trigger	*	70	75	C		
Output voltage (12V)	V-AUX	12	12	12	V _{Dc}	Regulated	3W MAX
AUX_1 output current	I _{V-AUX}	*	125	150	mA		
Output voltage (+-15V)	V-AUX2	5	*	18	V _{Dc}	Regulated	Based on order
AUX_2 output current	I _{V-AUX2}		50	100	mA		
In-rush current	2.5R NTC			*	A	TBD	
Efficiency	Full power	*	*	*	%	TBD	
Idle Losses	SMPS not loaded	*	*	*	W	TBD	SMPS is ON
Stand-by loss		*	*	*	W	TBD	SMPS in Stand By

Connector Pinouts 1/3

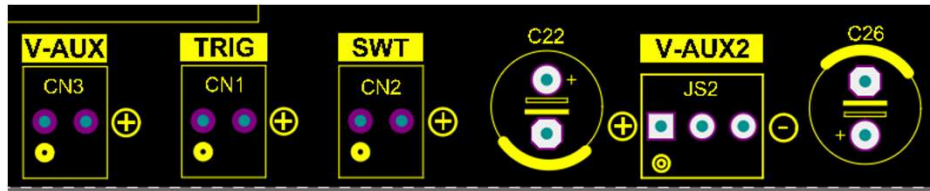

CN3 → V-AUX 12V (Standby power supply output) Always ON				
Connector	Pin number	Type	Function	Notes
CN3	+	Output	+12VDC	Positive rail
CN3	G	GND	GND	GND rail
JS2 → V-AUX2 +-15V (Regulated output)				
Connector	Pin number	Type	Function	Notes
JS2	+	Output	+15VDC	Positive rail (Regulated)
JS2	G	GND	GND	GND
JS2	-	Output	-15VDC	Negative rail (Regulated)
CN2 → SWT				
Connector	Pin number	Type	Function	Notes
CN2	CONTROL +	Input	Standby	Standby input control
CN2	CONTROL G	GND	GND	GND
CN1 → Trigger input 12VDC				
Connector	Pin number	Type	Function	Notes
CN1	+	Input	Trigger	+ Trigger input
CN1	G	GND	GND	GND

Connector pinout detailed description and operation

CN3 V-AUX

This output coming from the always ON standby power supply.
This output can be used to power any MCU or similar circuits.
Output voltage options for this output +5V or +12V.

JS2 V-AUX2

This output is the auxiliary regulated output of the SMPS, and its output voltage is determined by the installed voltage regulators. And can be anywhere from +-5VDC up to +-18VDC.
This output is protected with PTC.

CN2 SWT

This connector is where you will connect the ON / OFF switch that controls the SMPS on/off operation, shorting this connector will put the SMPS into **RUN MODE** opening this connector pins will put the SMPS into **STANDBY** mode. **Latching** switch is needed.

A latching switch is a switch that maintains its state after being activated.
A push-to-make, push-to-break

(SEE NEXT PAGE ON HOW TO WIRE THE SWITCH WITH LED)

Example:- <http://www.ulincos.com/product.php?id=55>

CN1 Trigger

This input controls the SMPS ON/OFF, applying any DC voltage between 5VDC ~ 12VDC will turn ON the SMPS.

SMPS control operation can be controlled via CN1 or CN2

Below is the wiring for the standby switch, with switches comes with LED inside.

You can use a switch without LED, it will also work.

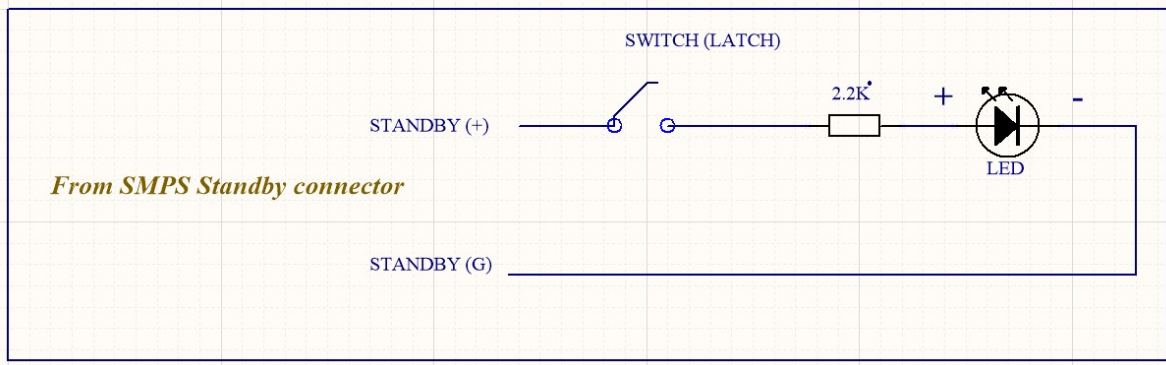

Example showing how to connect the switch
These switches usually has internal resistors
in that case external resistor is not needed

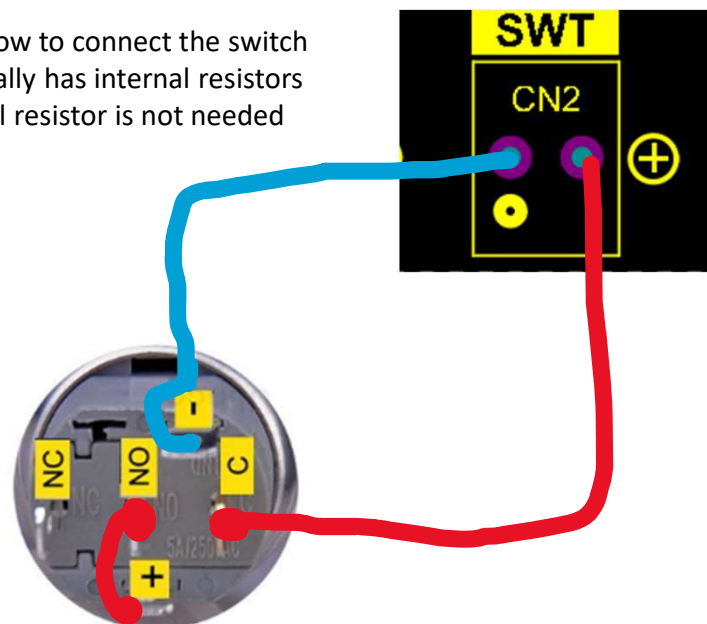

Mains AC – INPUT Connector & Voltage selector connector

Connector (J1) **CENTER PIN IS NOT USED**

Connector (J1) is the AC input connector from your mains, 110VAC or 240VAC

Connector (J2) is the voltage selector connector, see status below

(J2) OPEN = 240VAC Operation

(J2) CLOSED = 110VAC Operation

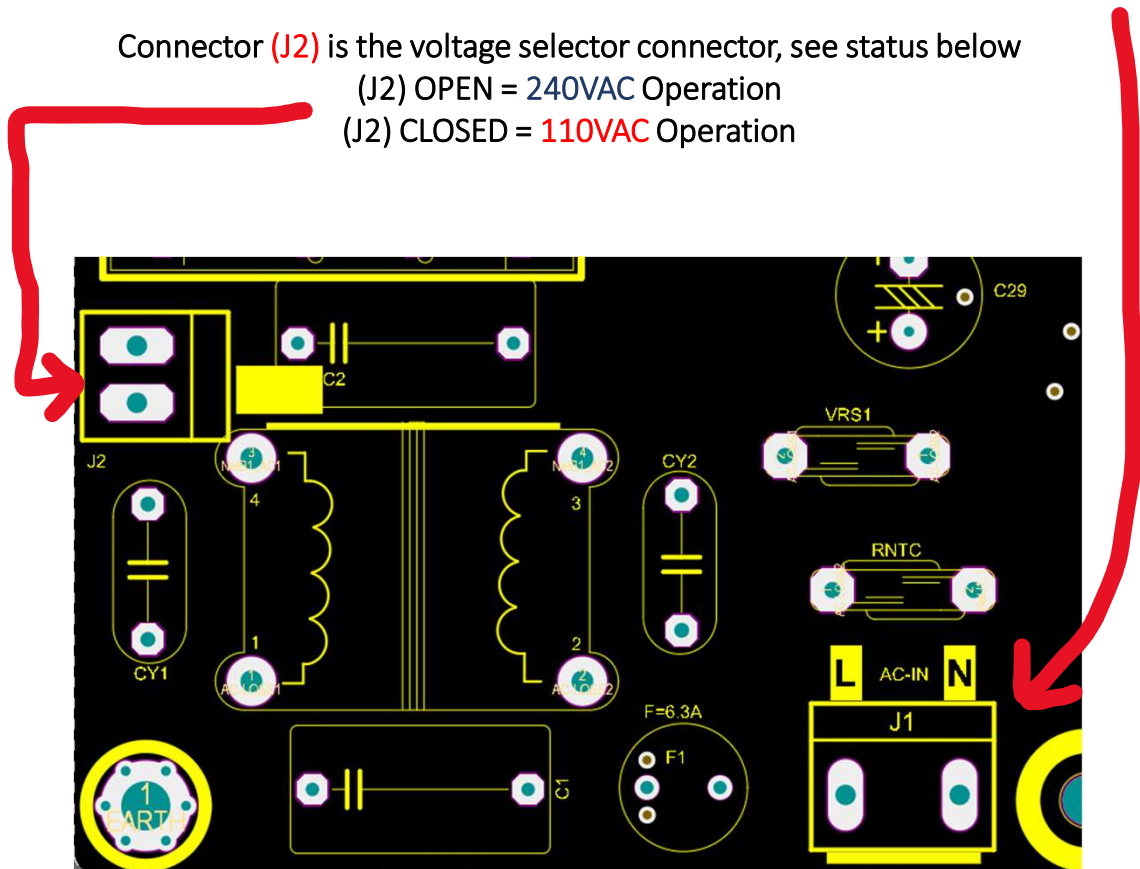

DC output pins

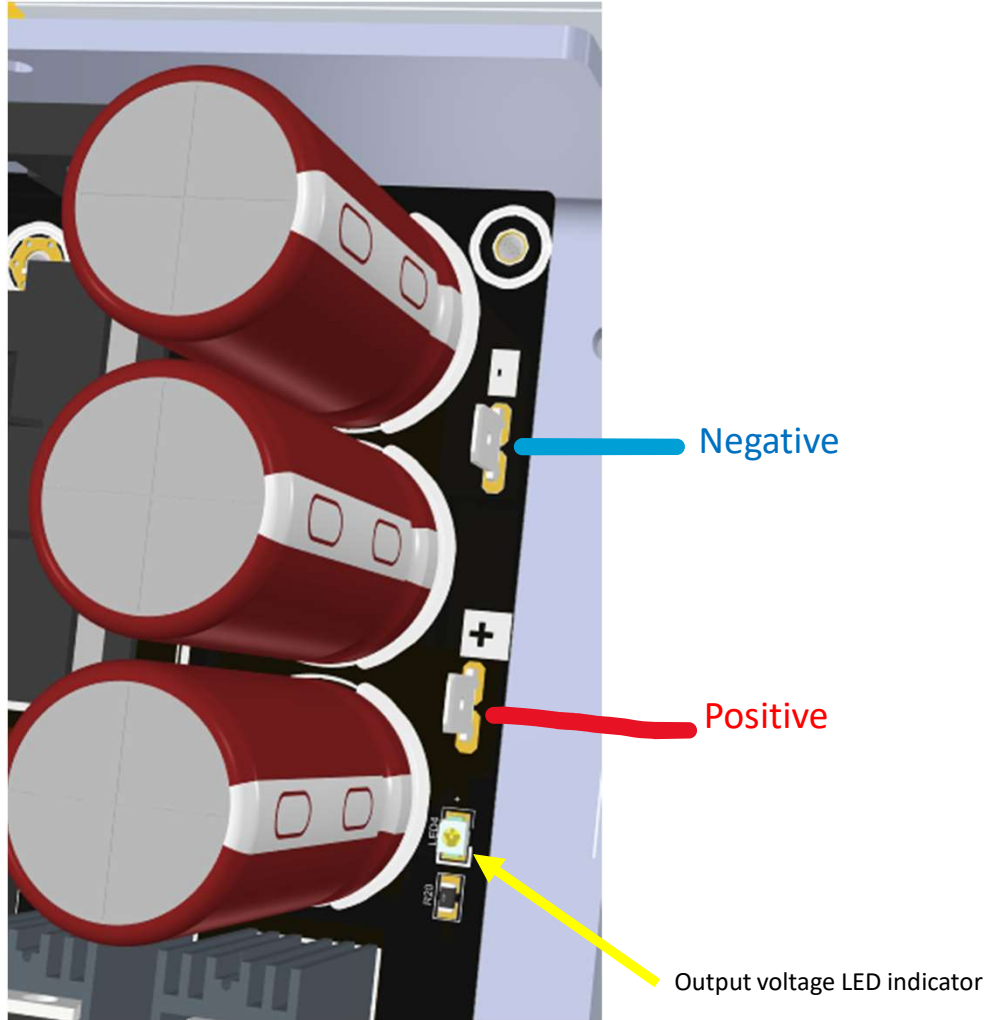

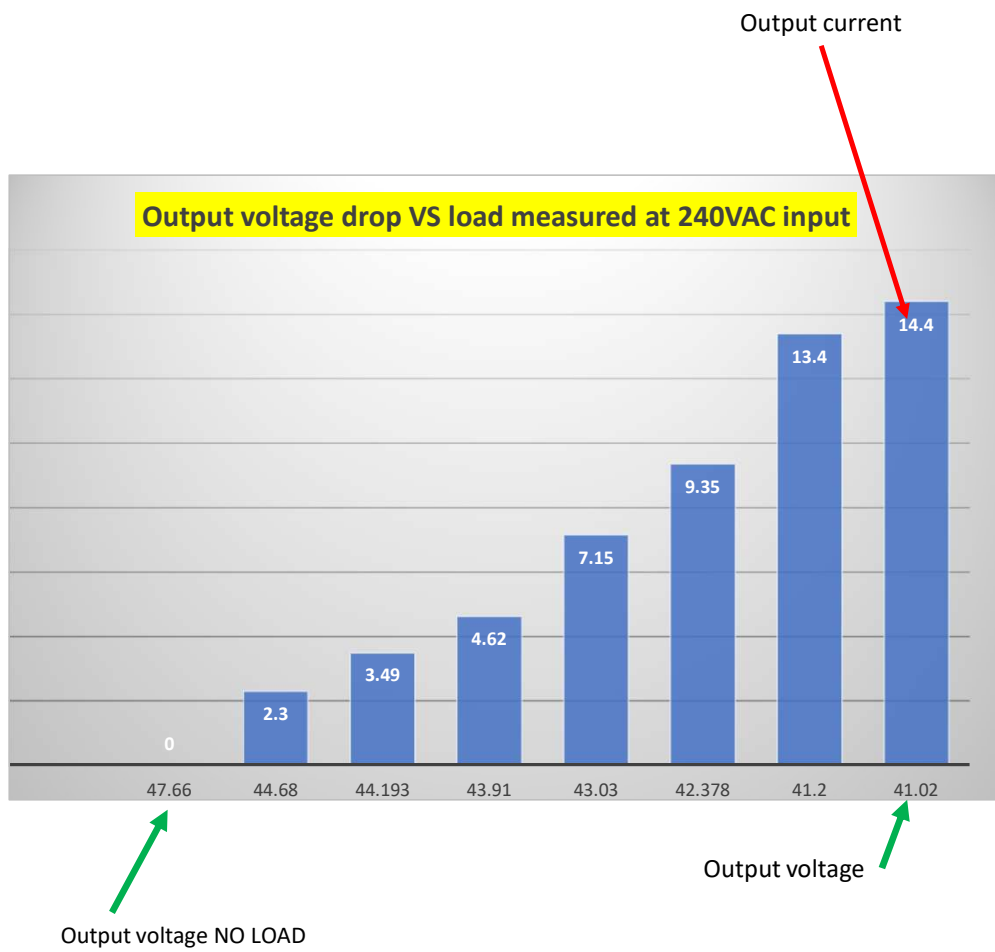

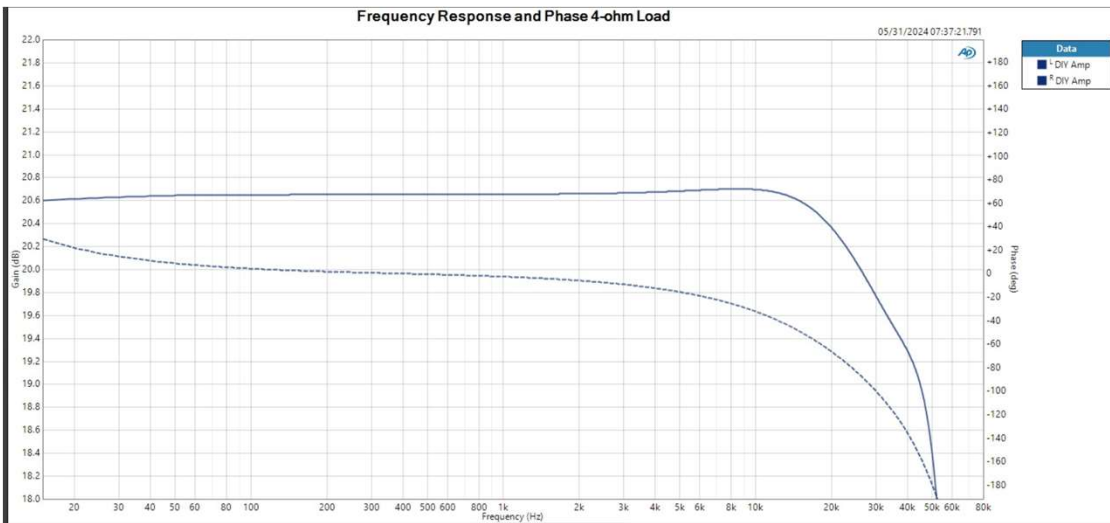
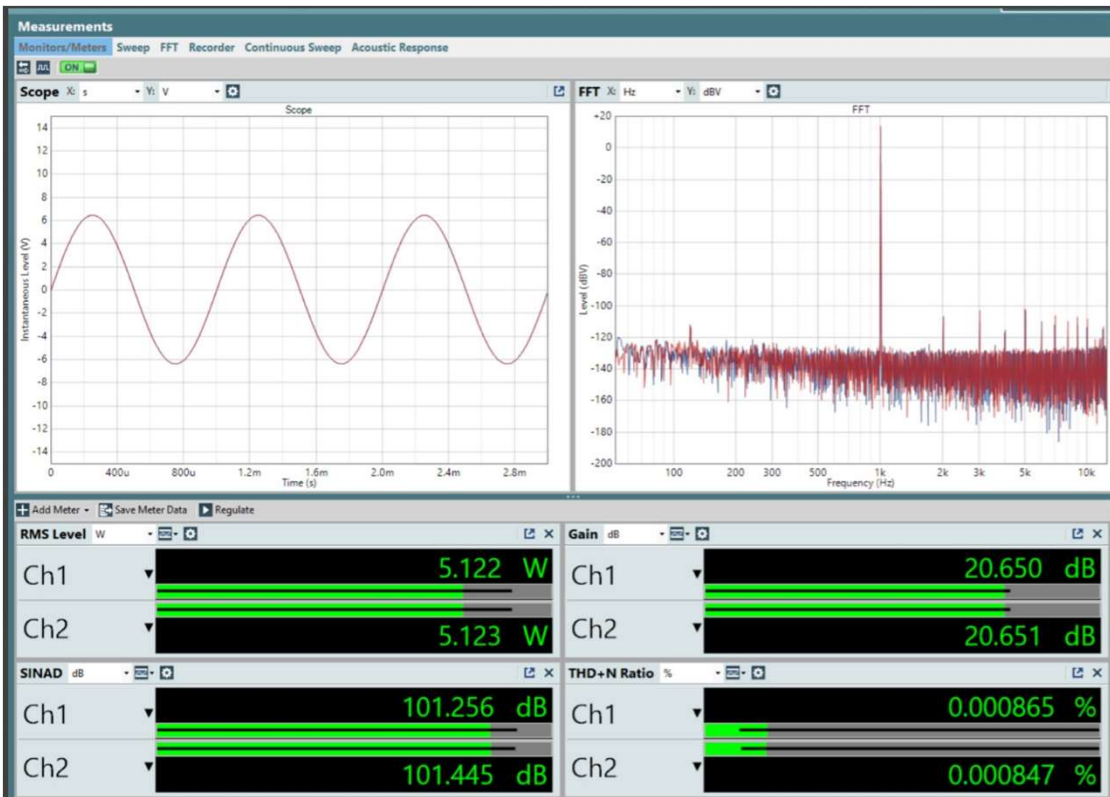
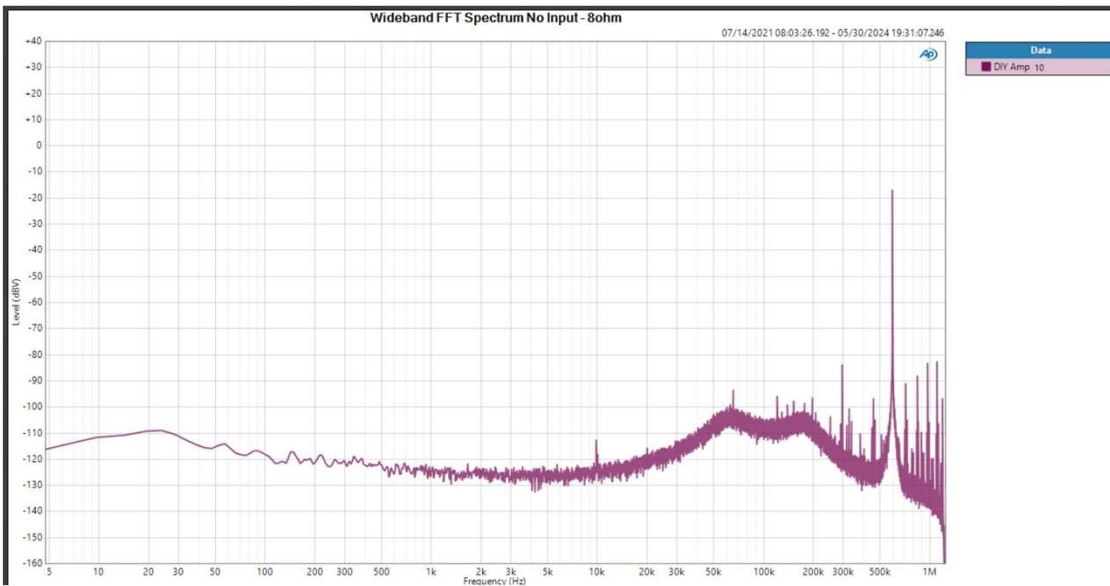

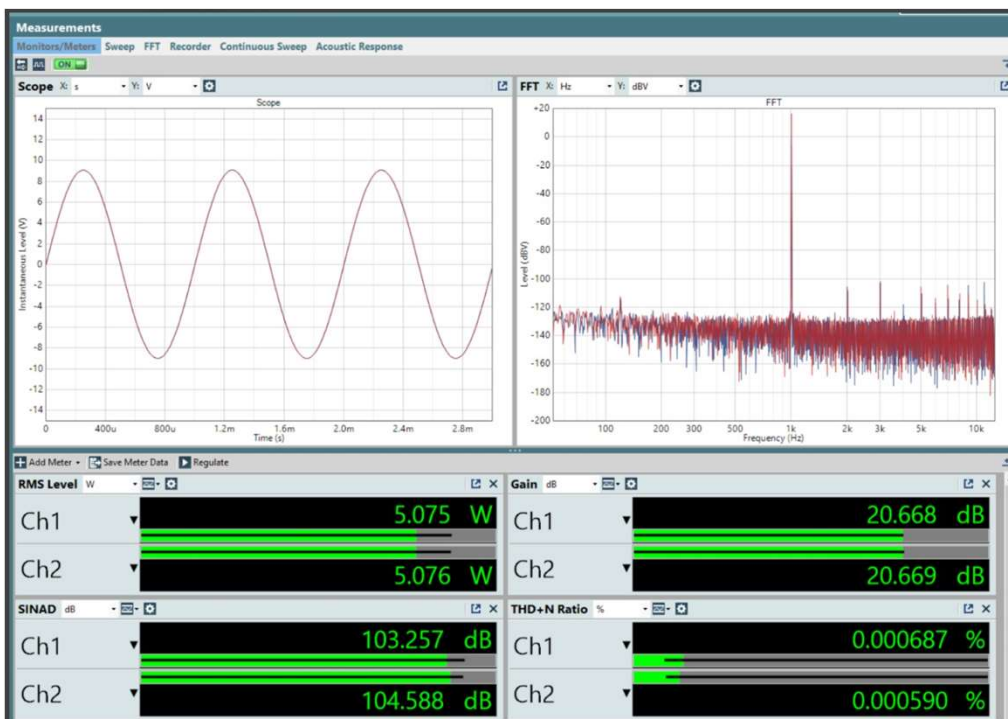
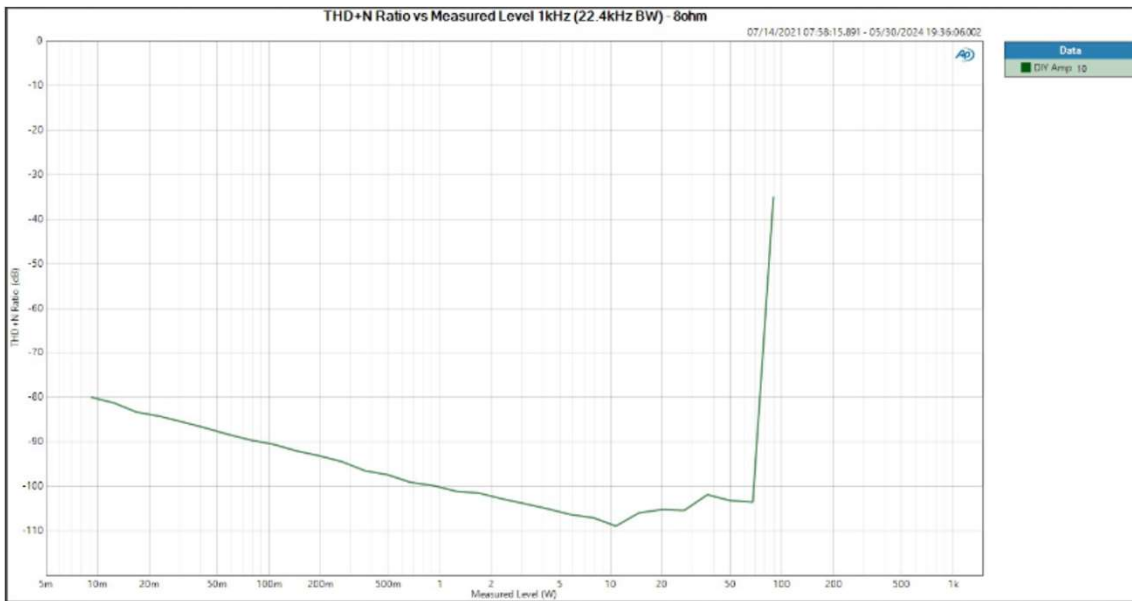
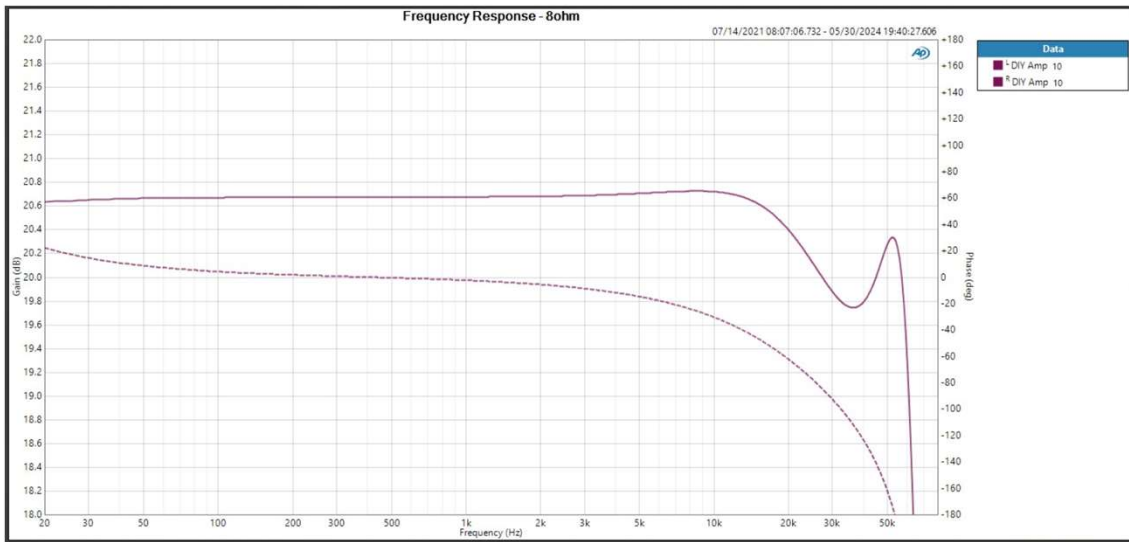

SMPS600-R2 in idle, no load
Room temperature 31C

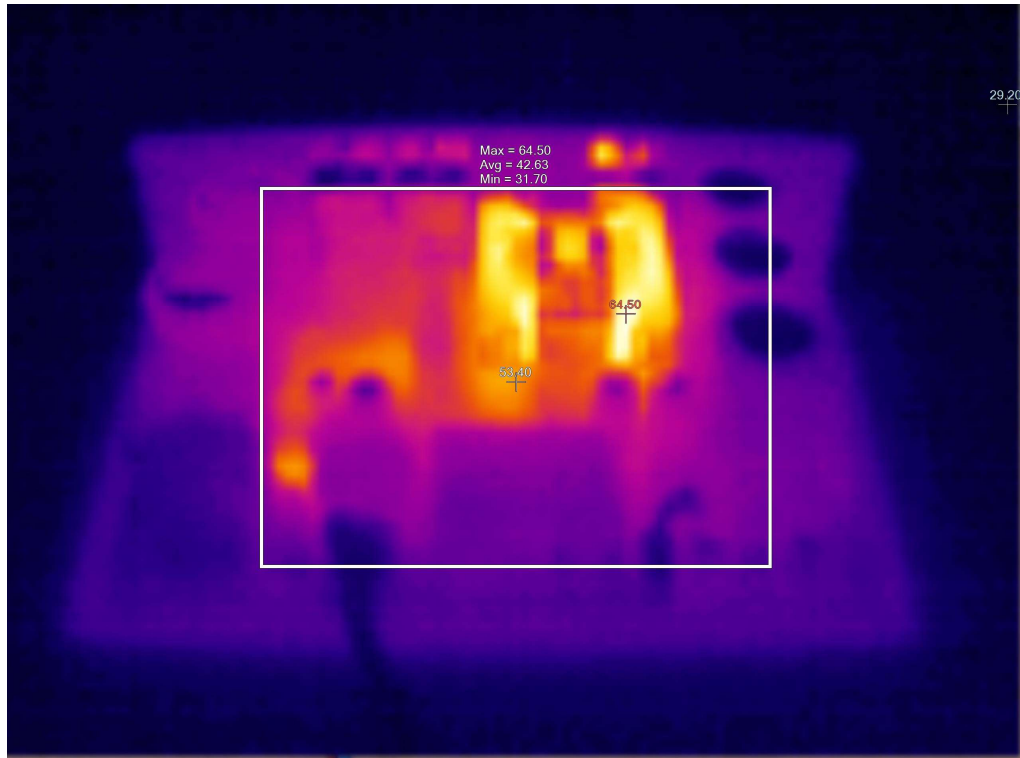

SMPS600-R2 Loaded 450W for 2 minutes

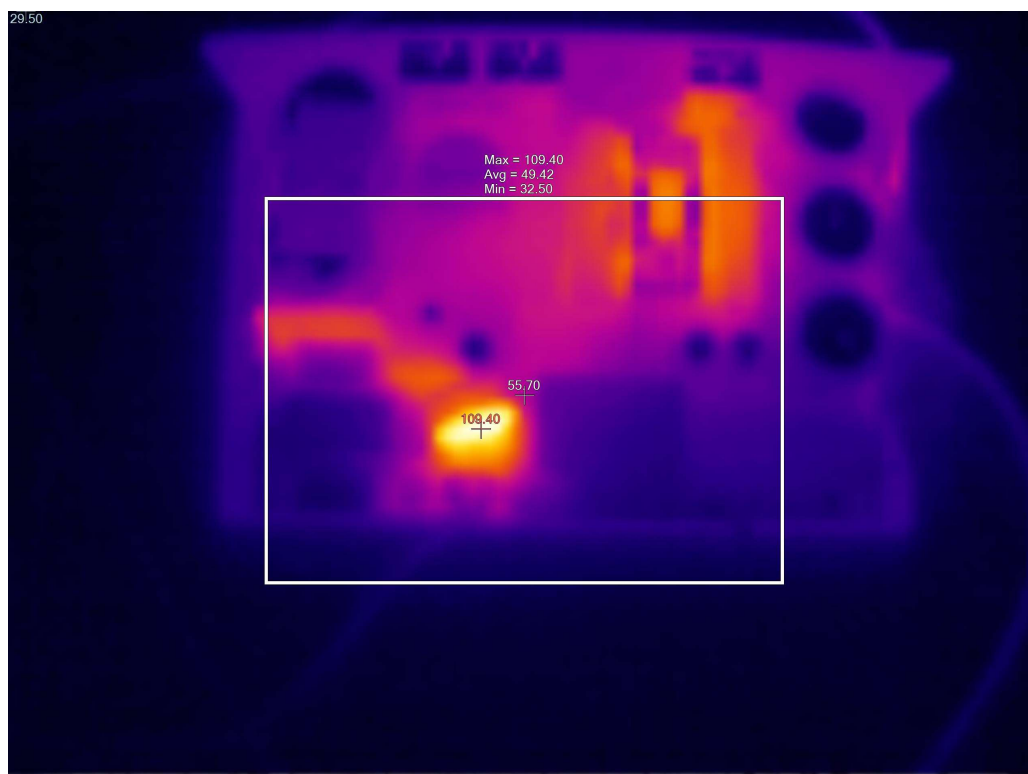

SMPS600-R2 Loaded 600W for 2 minutes



SMPS600-R2 Loaded 600W for 2 minutes

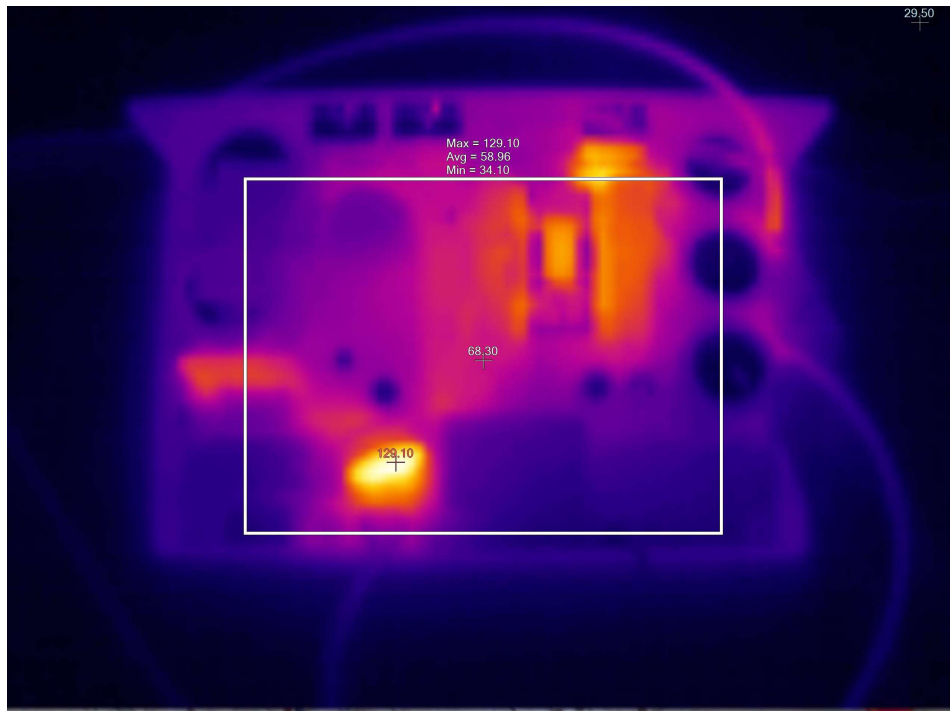

Power supply bus pumping

The SMPS600-R2 is an unregulated SMPS, therefore bus pumping will occur when used with **Class-d amplifiers ONLY**. A CLASS-D amplifier operates in half bridge mode.

Any CLASS-D amplifier operates in full bridge won't show the bus bumping effect.

There are two possible solutions to overcome this issue.

- 1- Use extra capacitance at the output of the SMPS
- 2- Operate your amplifiers in out of phase configuration, in stereo mode.



ELNA 10000uF 80V 35mm * 50mm



Extra capacitance PCB, accepts capacitors from 25mm up to 35mm

→ SMPS600-R2 could take up to 120000uF of extra capacitance at the output

NOTE-1 :

Empty PCBs for extra capacitors are available, please check availability based on your requirements.

Quality of components used

We only use the highest quality components into all the SMPS units we produce.

What you see in the picture is what you will get, you will get more than what you pay for.

We are not showing high grade components in the pictures and send you cheap chines parts like other SMPS manufactures do.

Our prices are better than others, we offer more features into our products with great technical support.

Our standard product line uses high grade parts, our custom versions uses higher grade parts based on customer request.



Technical Support

Technical support is more important than the product itself, we believe that a product without technical support is a dead product.

Our SMPS units are covered with 12 months warranty from the date of purchase.

All SMPS we produce can be fixed in case of any problem. As they are not made to be sent to trash if they fail like other manufactures do, we don't ask the customer to send the unit back to fix it and waste your valuable time.

Additional EMI / RFI noise filter

Using additional EMI / RFI noise filter is up to you, the SMPS has its own EMI / RFI noise filter , using additional filtering will not harm the installation.

→ Use only EMI / RFI noise filter from trusted manufacturers, don't use any cheap chines EMI / RFI noise filters.

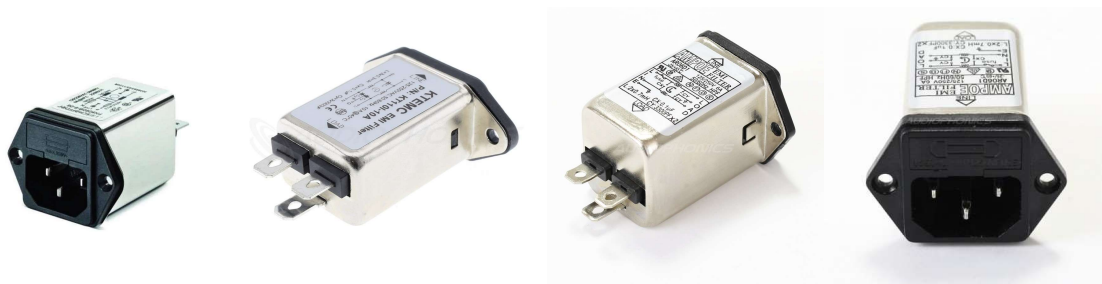

Disclaimer

All products, product specifications and data are subject to change without notice.

MicroAudio, all persons acting on its or their behalf (collectively, "MicroAudio"), disclaim any and all liability for any errors, inaccuracies or incompleteness contained in any datasheet or in any other disclosure relating to any product.

This module is designed for use in music reproduction equipment only. No representations are made as to fitness for other uses.

Except where noted otherwise any specifications given pertain to this subassembly only. Responsibility for verifying the performance, safety, reliability and compliance with legal standards of end products using this subassembly falls to the manufacturer end product.

LIFE SUPPORT POLICY: Use of MicroAudio products in life support equipment or equipment whose failure can reasonably be expected to result in injury or death is not permitted.